

zounds!

Zounds! is available online at kunm.org.

KUNM 89.9 FM Monthly Program Guide January 2007



Back at KUNM and LOVING It!

by Mary Oishi,
KUNM Development Director

“You’ll always have what you gave to love.”
—Beth Nielsen Chapman

That song lyric captures my experience with KUNM over the years as a staff member, then volunteer, and now as a staff member again. I can’t tell you how good it feels to receive such a warm welcome from the rest of my hard-working KUNM colleagues, the creative and devoted KUNM volunteers, and the wonderful KUNM community of listeners.

I look forward to leading the KUNM Development Department through many exciting projects in the year ahead. Since rejoining the department, we have diligently focused on putting everything in place necessary to keep improving our service to you, our valued members, in 2007. And it is a real joy for me to be a part of that—and of this amazing team.

We hope you will continue to find joy in giving to us as well—of your listening attention, of your means, and of your time—all of which shows your love for what we do here at KUNM. Believe me, we need it, we feel it, and it keeps providing the fuel for us to produce great radio 24 hours a day, 7 days a week.

Here’s my question to you for January: Do you want to show your love for KUNM in a way that is FUN—and you get good food and giveaways—PLUS great publicity for your favorite organization? Then ask your social, religious, student, civic, hobby or employee group to sign up for a

2 or 3-hour phone shift during our Spring Pledge Drive, scheduled to begin on Saturday, March 24th. If your organization sends out a monthly newsletter or email bulletin, this is a perfect time to pick a shift and recruit 4 to 8 people to staff the KUNM pledgeline phones. It gets publicity for your organization, you really help KUNM, and you all get to have a fun time together. Plus the KUNMers at this side of your radio signal have the opportunity to meet you too...and we love that!

It’s easy to do. We train you. We announce your organization several times throughout the shift. And we promise you’ll have a great time while helping KUNM. Just call Rachel Kaub (505-277-4516) to pick a shift—or maybe more than one!

Meanwhile, everyone in the Development Department wishes you a very Happy New Year! Thank you for being one of the many thinking, caring people who support KUNM. ■

KUNM
89.9 FM ALBUQUERQUE

KUNM Call-In Show
thursday 8am
live interviews with community leaders:
call in your comments and questions at 277-KUNM

one station, many voices
on 89.9 FM
streaming live at kunm.org
for a free copy of our program guide, call 505.277.3968, or visit kunm.org
simplified graphics studio | singell agnew photography

IN THIS ISSUE:

Glad to be back!	1
Joy to the KUNM community	3
Harlan McKasato comes back to NAC.....	6

Program Grid	8
Program Listings.....	9
Radio Highlights	10
Program Underwriters	14

KUNM Operations Staff

Sarah Beck Program Coordinator, Development
 Renée Blake News Director
 Tristan Clum Production Director
 Matthew Finch Music Director
 David House Information Systems Support Analyst
 Rachel Kaub Operations Manager
 Marcos Martinez Program Director
 Linda Morris Senior Fiscal Services Tech
 Mary Oishi Development Director
 Rob Raucci Member Services Coordinator
 Linda Rodeck Underwriting Marketing Specialist
 Steve Shadley News Director
 Mike Stark Chief Engineer
 Richard S. Towne General Manager
 Jim Williams News Director



Business line: 277-4806, toll-free 1-877-277-4806
Request line: 277-5615, toll-free 1-888-277-5615
Mailing address: MSC06 3520, 1 University of New Mexico,
Albuquerque, NM 87131-0001

KUNM Student Staff

Elaine Baumgartel Production Assistant
 Ana Benscoter Web Assistant
 Thomas Chavez Engineering Assistant
 Ogechi Chibueze Development Assistant
 Nick Gallegos PSAs/Administrative Assistant
 Sam Irons PSAs/Administrative Assistant
 Ramon Gallegos Operations Technical Specialist
 Roman Garcia Production Assistant
 Jennifer Jackson News Assistant
 Stephen Madrid Production Assistant
 Mercedes Mejia News Assistant
 Hannah Roen Bervig Music Assistant
 Jesse Sanderlin News Assistant
 Jeff St. Louis Operations Assistant
 Adriana Rico PSAs/Administrative Assistant
 Kamaria Umi Production Assistant
 Othiamba Umi Production Assistant

Email your comments or questions to kunm@kunm.org.
Your email will be forwarded to the appropriate staff person.

KUNM Radio Board

UNM Faculty Representatives:

Bryce Chakerian
 Iliia Rodriguez

Elected Community Reps:

Ed Gold
 Harry Horner, Chair
 Carolyn Ogren
 David Starr

Appointed At-Large Reps:

Vacant
 Carlos Sena

Paul Stokes ASUNM Representatives:

Nima Vadiie
 Vacant

GPSA Representative:

Vacant

University Staff Rep:

Ann C. Armendariz

Volunteer Representative

Linda Lopez McAlister

Ex-Officio Members:

Richard S. Towne, General Mgr.
 Marcos Martinez, Ops. Staff Rep.

KUNM Programming and Support Staff

Call 277-4516 for information on volunteer opportunities at KUNM.

Tara Abeta	Paolo Castillo	Rose Ebaugh
Cohni Acevedo	Marcelino Chalan Jr.	Jered Ebenreck
Adam Aguirre	Arcie Chapa	Emil Faithé
Joseph Aguirre	Ron Chapman	Kyle Farris
Brandi Ahmie	Cecilia Chavez	Missy Felipe
Marilyn Altenbach	Warren Cheromiah	Michele Ferm
Dennis Andrus	Halima Christy	Mark Fischer
Bill Baker	John Claussen	Dick Fredericksen
Jonathan Baldwin	Rufus Cohen	Tomás Garcia
CK Barlow	Ian Colburn	Craig Goldsmith
Dianna Baron-Moore	Meg Colby	Cynthia Gomez
Joseph Barron	Tanya Cole	Daniel Gonzales
Elaine Baumgartel	Allen Cooper	Gloria Gonzales
Spencer Beckwith	Neal Copperman	Henry Gonzales
Javier Benevidez	Lynn Coyle	Jason Gonzales
Steve Berman	Dan Cron	Paul Gonzales
Matt Bernstein	Gail Cunningham	Russell Goodman
Carrie Beverly	Kabir Daitz	Katie Graunke
Jane Blume	Vince Dawson	Wellington Guzmán
Mary Bokuniewicz	Wadell Dawson	Ron Hale
Carol Boss	Ed DeBuvitz	Michael Harle
Jeff Bray	Eva Del Rio	Louis Head
Tiffany Brazil	Rosemarie DeLeo	Cynthia Hernandez
Ron Bryan	David Denny	Danny Hernandez
Mayer Burgan	Don (Donaldson) DeNoon	Pamelya Herndon
John Burgund	Gwyneth Doland	Michael Hess
Derek Cadwell	M. Charlotte Domandi	Peggy Hessing
Ramon Calderon	Bob Dubin	Cindy Hong
Arturo Cardona	David Dunaway	Cheryl Hooks

Rebekah Horsechief	Sofia Martínez	Riti Sachdeva
David Hughes	Rachel Maurer	Nia Salgado
Ruth Imber	Don McIver	Travis Sandoval
Paul Ingles	Steven M. Miller	Maria Santelli
Mary Ellen Ipiotis	Francis Montoya	Ryan Schlee
Jim Jaffe	LeRoy Montoya	Stephen Schmidt
Pat Johnson	Evan Moulson	Christopher Shultis
Karen Johnston	Luna Natoli	Olivier Simon
Megan Kamerick	Carol Nez	Duane Smith
Aaron Kaufman	Beaver North Cloud	Robert Smith
Brandon Kennedy	Harry Norton	Stephen Spitz
Jaron Kie	Mike Orgel	Karl Stalner
Randy Kolesky	Robert Ottey	Ethan Stein
Barry Lauesen	Angelo Anselmo Pacheco	John Steiner
Reuben Last	Sebastián País	Claude Stephenson
Mark LeClaire	Travis Parkin	Joe Sullivan
Alan Ledergerber	Kent Paterson	Joe Tapia
Meena Lee	David Paytiamó	Jerome "Putnay" Thomas
David Lescht	David Percival	Jerry "Eeyo" Thompson
Glenda Lewis	Jula Pollitt	Ken Tohee
Alan Liddel	Cecilia Portal	Tracey Tram
Patti Littlefield	Chris Purcell	Mano Trujillo
Jonathan Longcore	Guillermina Quiroz	Shatinay Tuck
Linda Lopez McAlister	Roberta Rael	Anthony "Ijah" Umi
Susan Loubet	Cole Raison	Lucio Urbano
Avicra Luckey	Tom Rapisardi	Floyd Vasquez
Brigitte Lueck	Janet Riley	Yolanda Vielle
Kelly MacNeil	Philip Riley	Cecilia Webb
Scott MacNicholl	Jenna Ritchey	Mark Weber
Jason Marchiondo	Rogi Riverstone	Misty William
Paul Mathias	Sherrick Roanhorse	Diane Yanney
Chris Martín	Kelvin Rodríguez	Jason Young
Lucia Martinez	Giovanna Rossi	Anthony Zancanella
2 Luis Martinez	Kathy Sabo	Charlie Zdravesky

WISHING YOU THE JOY OF COMMUNITY RADIO

by Richard S. Towne, KUNM General Manager



This issue of our program guide goes to press a tad bit earlier than usual. With UNM closing for the winter break on December 21st, everything goes to production and the printer and the post office early to ensure you hear from us before the New Year.

While we continue to serve you with all of the news, music and cultural programs that you rely on, our offices will be closed in observance of the holidays and UNM's annual year-end closing. KUNM offices re-open on January 3rd. We will be rested and ready to help you in every way we can. If you are making a year-end gift to KUNM, we love you as always, and can provide you with tax acknowledgement just as soon as we are back in January.

The holiday break is a good one for KUNM's professional staff, including myself. For one, we confidently leave the station completely in the competent hands of the students and volunteers who excel at great radio every day of the year!

My big kudos to Operations Manager Rachel Kaub and Chief Engineer Mike Stark for staying "on-call" and available to help if the need arises over the holidays. Big hoorays to Sarah Beck, as well! Sarah will be in a couple of times to take care of our program logs – the minute-by-minute, hour-by-hour internal list of what goes on the air when. You might not even know we have a program log, but Sarah makes it every day and without her help, we would be navigating without a map.

Rest assured, we will remain in tune with breaking news on the local, national and international stages. We are always responsive should the need arise. As always, we hope the need does not arise.

Absent any special needs at KUNM, we will take the holidays to relax, refresh and rejuvenate. We will each do those things that make the holidays so special everywhere.

We'll surely raise a warm and steamy mug of thankfulness to you for helping KUNM with your support.

One of our best kept secrets is how hard we work to make great radio -- radio that is magical, useful, engaging

and fun – a radio listening destination where you never, ever notice how hard we work to make the radio so tasty. Even Ebenezer Scrooge would smile if he could see how we make the radio.

Every fantastic day of the year, our staff members take on hundreds of tasks and transactions – all of them important -- most of them invisible to our listeners. Be the tasks little or large, I value all of our work together as it aggregates and accumulates into the very best community radio we can share with you. Hooray for the work we do together!

There is a real and tangible joy in our work! We place a premium value on serving you well. We're honored that you choose to listen and participate with us. As busy as we are, and as busy as we will always be, I do hope you will join me in recognizing the value and significance our collective work to make KUNM a significant part of our collective worlds. ■

A promotional graphic for KUNM. At the top is the KUNM logo, a diamond shape with a mountain and sun inside, flanked by horizontal lines. Below it is the text "K·U·N·M" in a stylized font, with "89.9 FM ALBUQUERQUE" underneath. The main image is a black and white photograph of a man wearing a patterned shirt and a cap, sitting and looking towards the camera. Below the photo, the text reads "Iyah Music" in a bold font, followed by "thursday 7pm" and "reggae and roots; a spectrum of african-influenced music". At the bottom, the text "one station, many voices" is written in a script font, and "on 89.9 FM" is written in a large, bold font. To the right of "89.9" is the text "streaming live at kunm.org". At the very bottom, it says "for a free copy of our program guide, call 505.277.3968, or visit kunm.org" and "simplified graphics studio | singeli agnew photography".

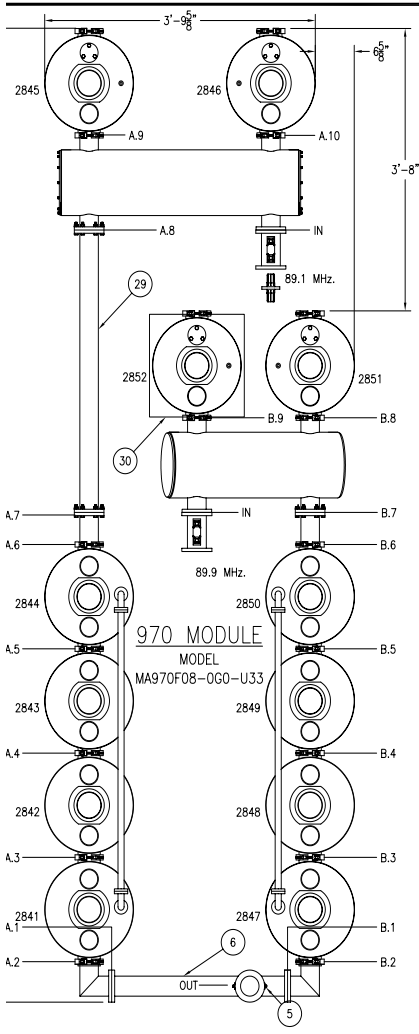

- NOTES:
- 1) *BILL OF MATERIAL REFLECTS HARDWARE INCLUDED TO ATTACH INPUT AND OUTPUTS OF SYSTEM.
 - 2) MULTIPLEXER ASSEMBLY IS COMPOSED OF TWO SYSTEMS EACH HALF IS REPRESENTED IN THE SIDE VIEW
 - 3) ASSEMBLE MODULES BY CORRESPONDING NUMBERS & LETTERS.
 - 4) CONNECTIONS ARE DESIGNED BY BANK LOCATION AND CONNECTION NUMBER. EX: A.1 WOULD BE BANK "A", CONNECTION NO. 1.
 - 5) MODULE BANK IS COLOR-CODED FOR EASE OF INSTALLATION.
 - 6) ALL OVERALL DIMENSIONS ARE APPROXIMATE AND MAY VARY PER TUNING.

REVISIONS			
REV	DESCRIPTION	REV BY:	DATE
A	CHANGED FROM "I" LAYOUT TO "U" LAYOUT	BAM	7/21/05
B	CHANGED FROM STANDARD "U" TO SPECIAL CONFIG.	BAM	7/26/05

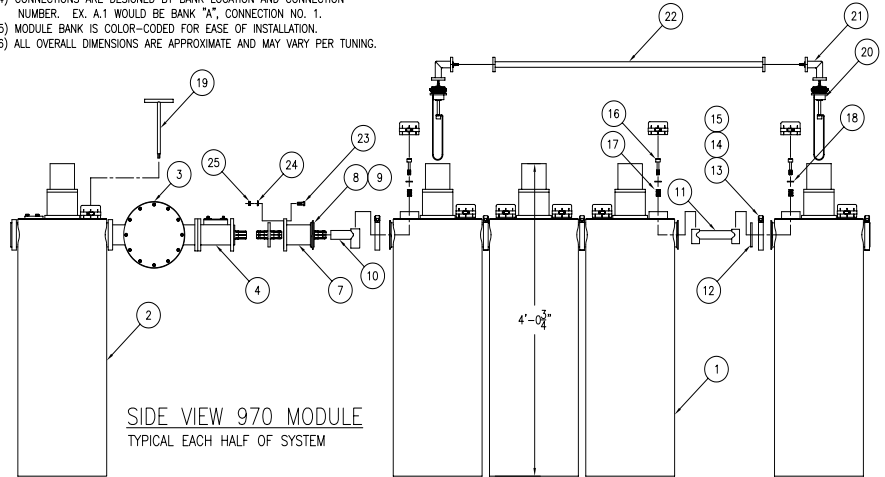

ITEM NO.	PART NO.	DESCRIPTION	QTY	ITEM NO.	PART NO.	DESCRIPTION	QTY
14	SC0518T0450	5/16"-18 X 4-1/2" LONG "T" BOLT	14	30	SR-1	SPECIAL ELEVATING RACK	1
13	CM0037	3" MARMAN CLAMP	14	29	CL-1	3 1/8" EIA LINE SECTION 44" LONG	1
12	FI0003	3" CONTACT RING	6	28	CE3022M	3 1/8" EIA - 3" MARMAN COAXIAL ELBOW	2
11	FI0132	INNER CONNECTING ASSEMBLY	6	27	*IN0028	3" "S" SPLIT WAFER INSULATOR	4
10	FI0131	3" INNER PORT CONNECTOR	8	26	*CC0021	3-1/8" IN-LINE BULLET	4
9	FI0006	CONTACT RING	2	25	*NU0616	3/8"-16 HEX NUT	36
8	IN0073	INSULATOR W/ CONTACT RING GROOVE	2	24	*WLO6SS	3/8" LOCKWASHER, SPLIT TYPE	36
7	CL3004	3-1/8" LINE SECTION MARMAN TO EIA	2	23	*SC0616H0150	3/8"-16 X 1-1/2" LONG HEXHEAD BOLT	36
6	CT3023	3 1/8" EIA TEE	1	22	CL-1	7/8" COAXIAL LINE SECTION	2
5	DC3005	DUAL DIRECTIONAL COUPLER	1	21	ACX150-10SE	7/8" ELBOW FLANGED EIA	4
4	DC3003	SINGLE DIRECTIONAL COUPLER	2	20	TL-1	SPECIAL TUNING LOOP	4
3	HY0040	10" HYBRID 3 1/8" EIA TO 3" MARMAN	2	19	FI0004	"T" HANDLE TOOL 1/2" SOCKET HEAD	1
2	FI0255	970 TYPE FILTER W/ 1 DOUBLE LOOPS	4	18	WF08SSA	1/2" FLATWASHER	20
1	FI0252	970 TYPE FILTER W/ 2 DOUBLE LOOPS	8	17	SG0001	SPRING	20
BILL OF MATERIAL				15	FI0220	1/2"-13 X 2" LONG STEPPED BOLT	20
				15	NU0518BZ	5/16"-18 BRONZE HEX NUT	14

ELECTRONICS RESEARCH, INC.
 Established 1943
ERI
 7777 GARDNER RD.
 CHANDLER, IN. 47810-9837
 PHONE: (812) 925-6000
 FAX: (812) 925-4030

This document/drawing contains information considered confidential by Electronics Research, Inc. (ERI). This information is disclosed on a confidential basis and only authorized for use in the installation, operation, and maintenance of ERI tower and antenna equipment, on appropriate. Reproduction, transmission or disclosure to others, or unauthorized use, without the express written consent of ERI, is strictly prohibited. UNAUTHORIZED REPRODUCTION OR DISCLOSURE OF THIS INFORMATION IS A VIOLATION OF FEDERAL LAW.
 * COPYRIGHT 2005 ERI, ELECTRONICS RESEARCH INC.

SUPERSEDES DWG #:	APPROVED	DATE	0.0 ± 0.03	NAME COMBINER ASSEMBLY DETAIL DRAWN: KANW/KUNM - ALBERQUERQUE, NM. FREQUENCY: 89.1 & 92.9 MHz, PROJECT NO.: 15280 PATH: G:\DRAFTING\ALL PROJECTS\15280 FILE: IM - 1.E DRAWN: BAM DATE: 7/20/05 SCALE: 1/161 DWG. NO.: 1 OF 1 TOLERANCES: UNLESS SPECIFIED OTHERWISE
SUPERSEDES FILE #:	DRAFT		0.00 ± 0.01	
MATERIAL:	ENG.		0.000 ± 0.003	
	MANUF.		± 1/32" ± .5"	

The KUNM Combiner: It's not pretty, it's necessary!

It's not much to look but looks can be deceiving. Now that our new digital transmitter is in place one of the final pieces of the puzzle that remains is the combiner.

The combiner is a large (4'H x 5'W x 12'L approx.) and weirdly looking piece of gear that looks like a bunch of little garbage cans set up in parallel rows (see illustration above). The combiner is installed on the floor inside the transmission building (so it's not so strongly affected by outside weather conditions as any work on the tower can be). The combiner does what its name implies. It combines KUNM's transmitter and KANW's transmitter into a signal that can be transmitted by a single antenna (pardon the lay-person's speak here). The wrong size combiner had been specified in the earlier days of this project. A couple of days will be needed to remove the wrong-sized combiner and the 20-year-old combiner, and finally install the new combiner.

As of this writing the new combiner has been de-

livered. However, it has yet to be assembled by the manufacturer's field crews. Once the combiner is fully installed and calibrated, KUNM can contemplate its increase in effective power (about 30%) as authorized recently by the FCC. This should be a straight forward process since the transmitter KUNM purchased and installed in 2003 has been revised to handle this increase. Somewhere along the way, KUNM will also need to have outside engineers help us with calibrating and fully optimizing the transmission chain and antenna output for maximum benefit. This may result in temporary low power operations but will be the final bit of work needed at the Crest.

At this point, we don't have a completed timeframe for the power upgrade. According to KUNM Chief Engineer, Mike Stark, an FCC site survey which covers safety issues, RF exposure to workers and a report on work already completed. Once the mandated site survey is approved, we will see our power upgrade. The antenna optimization has also not been scheduled at this point since so many other factors need to fall into place first. ■

What is HD Radio?

HD Radio broadcasting is dramatically higher quality audio, far more programming choice and compelling new wireless data services brought to you by your local AM and FM radio stations. No more static, hiss, pops or fades.

Today, thousands of radio stations are upgrading their broadcast technology; hundreds are currently broadcasting with digital HD Radio technology, with many also offering new HD2 multicast channels. Your favorite station remains in the same place on the radio dial, but when you have a new digital HD Radio receiver, your AM sounds like FM and FM sounds like CDs. In addition, the wireless data feature enables text information – titles, artists, weather or traffic alerts – to be broadcast directly to your receiver's display screen. And, FM HD Radio stations are starting to "multicast," offering more than one stream. Simultaneously, one station can offer several audio channels as well as on-screen data. A station can run one channel of music and one of news, or two different music formats. Or run three completely different music formats in three different languages. And much, much more.

Approved by the Federal Communications Commission in October 2002 as the only system for digital AM and FM broadcasting in the U.S., HD Radio technology is developed and licensed by iBiquity Digital Corporation and supported by the leaders of the broadcasting, consumer electronics and automotive industries. ■

How HD Works . . .

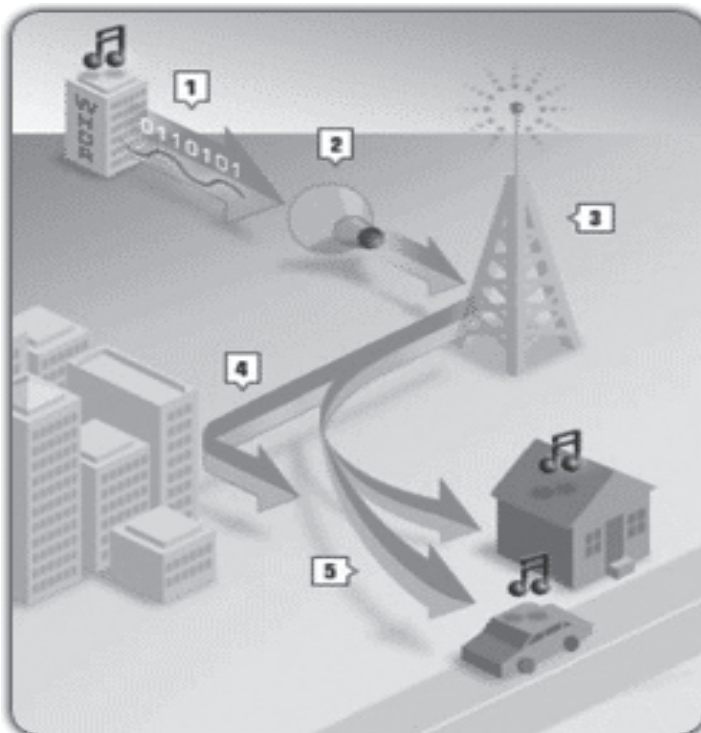

1. Stations bundle analog and digital audio signals (with textual data, such as artist and song information, weather and traffic, and more).
2. The digital signal layer is compressed using iBiquity's HDC compression technology.
3. The combined analog and digital signals are transmitted.
4. The most common form of interference, multipath distortion, occurs when part of a signal bounces off an object and arrives at the receiver at a different time than the main signal. HD Radio receivers are designed to sort through the reflected signals and reduce static, hiss, pops and fades.
5. The signal will be compatible with HD Radio receivers and analog radios ■

We gratefully acknowledge the iBiquity Digital Corporation for the information contained in this article.



NM Tech
Performing
Arts Series

(505) 835-5688 • nmtpas.org

Presidential Chamber
Music Series Free Admission
Friday, January 26

Piano Quartets featuring
Awadagin Pratt



Viver Brasil
Friday, February 2
\$14/a, \$12/sr, \$10/yth

The multi-award winning Viver Brasil Dance Company explores ancient and contemporary art forms and the spiritual strength of Brazilian culture in this "Brazilian to the core" production.

Imani Winds
Tuesday, February 27
\$14/a, \$12/sr, \$10/yth

Pushing new cultural and musical bounds with its deeply personal repertoire, Imani Winds dares to take the wind quintet where it rarely ventures.



Shows begin at 7:30 pm at Macey Center in Socorro.
Just one hour south of Albuquerque!

The prodigal returns! Harlan McKasato is back as host of Native America Calling

With the familiar strumming of “Back in the Saddle Again” playing in the background, Harlan McKasato has once again taken hosting chores for Native America Calling. After the song ended Harlan quickly pointed out that while he’s back in the saddle “the warrior in me says I don’t need a saddle. I’m back on the Appaloosa bareback style.” Harlan (Sac & Fox) assumed the host’s chair with the country’s only national Native radio call-in talk show on Monday, December 4, 2006. McKasato’s voice is familiar to NAC listeners because he served as the host of NAC for several years.



NAC’s Harlan McKasato

McKasato is an award winning journalist who has worked in print, radio and television and has created and implemented a youth leadership program for American Indians. Harlan has a Bachelor of Arts degree in Journalism & Mass Communication from the University of Oklahoma.

KBC’s COO-National, Susan Braine, said, “Harlan is a remarkable journalist and our listeners have really responded to programs he hosted for NAC in the past. We’re excited to have him on board.”

Harlan joins recent additions to the NAC staff with the hiring of Ethan Stein, Production Engineer, and Merritt Youngdeer, Associate Host and Producer. Patty Talahongva hosted NAC from May, 2004 to mid-November, 2006, when she left the program.

The mission of Koahnic Broadcast Corporation is to be the leader in bringing Native voices to Alaska and the nation. Koahnic Broadcast Corporation, one of the country’s leading national Native media enterprises, operates four main divisions: KNBA-FM 90.3, the country’s only urban, Native-controlled public radio station; national radio programming, including National Native News, Earthsongs, Native America Calling, and UnderCurrents (co-produced with Radiocamp); and the national program distribution center, Native Voice One; and a media training center for Alaska high school students, MEDIAC (in partnership with Cook Inlet Tribal Council, Inc.) ■

THE FUTURE BEGINS TODAY



PLANNING YOUR FUTURE & KUNM'S

KUNM is funded primarily by financial contributions from listeners like you. More than 50% of our annual budget comes from your support. If you want to help ensure the future of live, locally owned and operated, independent public radio, please consider a planned gift today.

Complete this form for information on how future Charitable Gifts to KUNM can help. You are under no obligation and KUNM will not contact you, unless you request us to do so.

Name _____

Address _____

Telephone (if you would like to be contacted by phone) _____

E-mail _____

Please contact me by:

mail phone e-mail

Please check one or more of the following:

- I want to consider an estate gift/bequest
- I am interested in making of a gift of stock, real estate, or retirement assets
- I would like to receive information on planning a gift to KUNM through my will, retirement plan, insurance policies or other financial plans
- I have included KUNM in my will/estate plan and wish to be recognized
- I have included an anonymous gift to KUNM in my will/estate plan

Mail or fax this form to:

**KUNM Membership
MSC06 3520
1 University of New Mexico
Albuquerque, NM 87131**

For more information, call: 277-3968, or e-mail: membership@kunm.org

Talk Back to Your Radio

NPR mailing address: National Public Radio, 635 Massachusetts Ave. NW, Washington D.C. 20001-3753

NPR Audience Services 1-202-414-3232

National Public Radio, transcripts and tapes:
1-877-NPR-TEXT (1-877-677-8398)

Transcripts are \$10, plus \$1.50 shipping and handling, tapes are \$12.95, plus \$2.50 shipping and handling. Programs:

**Morning Edition, All Things Considered,
Weekend Edition, Weekend All Things Considered**

Transcripts can also be accessed on the Nexus database.

NPR listener comment lines:

Morning Edition 202-842-5044
Performance Today 202-842-3522
Weekend Edition Sunday 202-371-1775

Internet & email addresses, national programs:

Afropop Worldwide: afropop@pri.org
All Things Considered: atc@npr.org
Living on Earth: loe@npr.org
Morning Edition: morning@npr.org
Performance Today: perftoday@npr.org
StarDate: stardate@astro.as.utexas.edu, <http://stardate.org>
This American Life: <http://www.thislife.org>
This Way Out: tworadio@aol.com
Weekend All Things Considered: watc@npr.org
Weekend Edition Sunday: wesun@npr.org

KUNM e-mail addresses:

KUNM@kunm.org
Marcos Martinez, Program Director programming@kunm.org
Richard S. Towne, General Manager richardtowne@kunm.org
Rachel Kaub, Operations Manager operations@kunm.org
Mary Oishi, Development Director maryoishi@kunm.org
Sarah Beck, Program Coordinator support@kunm.org
Rob Raucci, Member Services Coordinator membership@kunm.org
KUNM home page: <http://kunm.org>
Ear to the Ground: kunmear@unm.edu
Radio Theater: art@unm.edu

FAIR (Fairness and Accuracy in Reporting, produces **Counterspin**, Tuesdays at 8:30 a.m.), 130 W. 25th St., New York, NY 10001. For subscription information on their magazine *Extra*: 1-800-847-3993

Living on Earth comment line: 1-800-218-9988. Mailing address: Living on Earth, PO Box 639, Cambridge, MA 02238. Tapes/transcripts available, \$10.

Bioneers: 6 Cerro Circle, Lamy, NM 87540; 1-877-BIONEER, online at bioneers.org

Alternative Radio: www.alternativeradio.org, info@alternativeradio.org 1-800-444-1977; PO Box 551, Boulder, CO 80306

CCNS Weekly News Update: www.nuclearactive.org
Hotline: (505) 982-5611; 800-456-8863

StarDate: 1-800-STARDATE; 2609 University Ave. #3.118, Austin, TX 78712.

This Way Out, PO Box 38327, Los Angeles, CA 90038;
phone 818-986-4106.

Native America Calling: Produced by Koahnic Broadcast Corp. at KUNM; 277-7999.
Call-in number: 1-800-99-NATIV. For comments or program copies e-mail: comments@nativeamericacalling.com or fax request to 505 277-4286.

WINGS (Women's International News Gathering Service): PO Box 33220, Austin, TX 78764; 512-416-9000; wings@igc.apc.org

YOU MAKE PUBLIC RADIO POSSIBLE!

KUNM is funded in part by financial contributions from listeners like you. More than 50 percent of our annual operating budget comes from listener support. If you're listening to KUNM, please help pay for it! Complete this form and mail it with your tax-deductible gift to:

**KUNM-FM Development Department
MSC06 3520, 1 University of New Mexico
Albuquerque, NM 87131-0001**

Name _____

Address _____

City _____

State _____ Zip _____

Phone _____

Amount:

- | | |
|----------------------------------|--|
| <input type="checkbox"/> \$1,000 | <input type="checkbox"/> \$75 |
| <input type="checkbox"/> \$ 500 | <input type="checkbox"/> \$60 |
| <input type="checkbox"/> \$ 240 | <input type="checkbox"/> \$40 (basic membership) |
| <input type="checkbox"/> \$ 120 | <input type="checkbox"/> \$20 (students/seniors) |

Please check one:

- Payment enclosed**
 Charge to VISA/Mastercard

Card Number _____

Exp. Date _____

Automatic bank transfers make it easier than ever to support KUNM! Join the KUNM CARETAKER CLUB and you can automatically transfer \$5 or more each month from your bank account to ours. For details, call 277-3968.

A gift of \$75 or more entitles you to the KUNM MemberCard, with two-for-one offers at nearly 200 restaurants and attractions throughout New Mexico.

Please send me a KUNM MemberCard.

Pledge of \$20 or more includes a one-year subscription to *Zounds!*, KUNM's monthly program guide.

Check here if you DO NOT wish to receive *Zounds!*

Questions? Call 277-8006 or 277-3968.

SUPPORT PUBLIC RADIO!





	monday	tuesday	wednesday	thursday	friday	saturday	sunday		
5:00	morning edition 5-8:30am MTWF 5-8am TH					overnight freeform		5:00	
6:00						new dimensions 6-7am	train to glory 6-9am	6:00	
7:00						weekend edition 7-9am		7:00	
8:00	latino USA 8:30-9am	counterspin 8:30-9am	living on earth 8-9am	call-in program 8-9am	public affairs 8:30-9am			8:00	
9:00	performance today 9-11am					children's radio hour 9-10am	weekend edition sunday 9-11am	9:00	
10:00	performance new mexico a 5-minute feature on local events, airs at 9:01am and 10:01am					folk routes 10-Noon		kunm specials 11-Noon	10:00
11:00	native america calling 11-Noon							11:00	
Noon	kunm news at noon Noon-12:05pm					women's focus / voces feministas Noon-2pm	singing wire Noon-4pm	Noon	
1:00	all that jazz Noon-1:30pm								1:00
2:00	freeform 1:30-4pm					raíces 2-5pm		2:00	
3:00			grassroots nm 3:55-4pm					3:00	
4:00	democracy now 4-5pm						this american life 4-5pm	4:00	
5:00	all things considered & KUNM's New Mexico news 5-7pm					all things considered 5-6pm		5:00	
6:00						alternative radio 6-7pm	radio theatre 6-7pm	6:00	
7:00	raíces 7-10pm	home of happy feet 7-10pm	the blues show 7-10pm	iyah music 7-10pm	salsa sabrosa 7-10pm	ear to the ground 7-8pm	youth radio 7-8pm	7:00	
8:00	espejos de aztlan 8:00pm					hot lix 8-10:30pm	spoken word 8-9pm	8:00	
9:00							other voices other sounds 9-11pm	9:00	
10:00	global music 10pm-1am	music to soothe the savage beast 10pm-1am	southwest stages 10-11pm	fresh 10pm-1am	afropop worldwide 10-11pm	psychedelic radio head shoppe 10:30pm-1am		house that jazz built 11pm-1am	10:00
11:00			tombstone rock 11pm-2am					11:00	
Midnite	freeform 7 days a week					coffee express 1-3am	cyberage 1-3am	Midnite	
1:00								1:00	
2:00								2:00	
3:00								3:00	
4:00	<i>KUNM runs many specials, topical and seasonal programming. Please check our website at www.kunm.org for info about special programming.</i>					<i>stardate your two-minute guide to the galaxy runs M-F at 7pm; weekends at 6pm</i> <i>national native news can be heard M-F from 11:01-11:06am</i> <i>independent native news can be heard M-F from 5:24-5:29pm</i>			4:00

public radio for northern and central new mexico //// www.kunm.org //// KUNM is in the Mountain Time Zone: 2 hours earlier than Eastern Time) and +7 hours GMT



PROGRAM LISTINGS

Afropop Worldwide Fri. 10 p.m. Music with an African influence from around the world.

All That Jazz M-F noon. Jazz, straight ahead to fusion.

All Things Considered M-F 5 p.m., Sat. & Sun. 5 p.m. Award-winning news magazine from NPR.

Alternative Radio Sat. 6 p.m. The view from the other side, from some of the most progressive writers, thinkers and activists of our time.

The Blues Show Wed. 7 p.m. The spectrum of blues music, plus interviews, live performances, and blues news.

Call-In Show Thur. 8 a.m. Live interviews with community leaders; call in your comments and questions at 277-KUNM.

CCNS Update Sat. 8:34 a.m. Concerned Citizens for Nuclear Safety presents the latest local, national and international news about nuclear issues.

Children's Radio Hour Sat. 9 a.m. Stories and music for children of all ages.

Coffee Express Fri. 1-3 a.m. Live, improvised music, voice, effects and sound collages, combined with on-air phone callers, CDs and records, tape loops, internet audio, etc. It's not jazz, but it is caffeinated.

Counterspin Tues. 8:30 a.m. A critique of the week's news coverage by other media, from FAIR.

Cyberage Sun. 1-3 a.m. Innovative electronic music of all sub-genres; elektro, industrial, ebm, ambient, power noise, synthpop, techno and drum 'n' bass.

Democracy Now M-F 4 p.m. From Pacifica, diverse commentators focus on the issues affecting individuals and society.

Ear to the Ground Sat. 7 p.m. A local music showcase, featuring live performances by local talent.

Espejos de Aztlan Mon. 8 p.m. Bilingual arts and public affairs program with interviews.

Folk Routes Sat. 10 a.m. A weekly sampling of the best in folk, blues to bluegrass and beyond.

Freeform Music M-F 1:30-4 p.m.; overnights. A diverse showcase of KUNM's music library, uncovering common roots in music from different places and times.

Fresh Thur. 10 p.m. New Mexico's international electronic and "new" music program featuring guest composers, artists and interviews.

Global Music Mon. 10 p.m. Exploration of music from around the world.

Home of Happy Feet Tues. 7 p.m. Folk music in the broadest sense of the term. Bluegrass, blues, cajun, zydeco, western swing, rockabilly, Tex-Mex, and more!

Hot Lix Sat. 8 p.m. Charlie Z. hosts a program of "oldies," commentary, dedications & requests, and special guests.

House that Jazz Built Sun. 11 p.m. Uncompromising creative music from the past 30 years.

Independent Native News 6:30 p.m. 5-minute program presenting current news about Native Americans.

Iyah Music Thur. 7 p.m. Reggae and roots; a spectrum of African-influenced music.

KUNM Specials Sun. 11 a.m. From public affairs to holiday specials, the latest and best in local and national production.

Latino USA Mon. 8:30 a.m. English-language radio journal of Latino news and culture.

Living on Earth Wed. 8 a.m. Weekly environmental news and information program, from NPR.

Morning Edition M-F 5-8:30 a.m. Award-winning morning news magazine from NPR.

Music to Soothe the Savage Beast Tues. 10 p.m. Progressive and indie rock culled from new releases you're not likely to hear anywhere else. Plus live and recorded local music.

Native America Calling M-F 11a.m. The nation's first live daily call-in program by, for, and about native people. 1-800-99NATIVE.

National Native News M-F 11:01 a.m. 5-min. newscast focusing on Native American issues.

New Dimensions Sat 6 a.m. Dialogues presenting a diversity of views from many traditions and cultures, with practical knowledge and perennial wisdom for a more healthy life of mind, body and spirit.

News at Noon M-F noon. News update from NPR.

Other Voices, Other Sounds Sun. 9 p.m. Contemporary music & sound art with an international perspective.

Performance New Mexico M-F 9:01-9:06, local arts calendar; 10:01-10:06 feature on upcoming local event; calendar listings on the web at kunm.org/perfm.

Performance Today M-F 9 a.m. A two-hour program of classical music performances, recorded live; from NPR.

Psychedelic Radio Head Shoppe Sat. 10:30 p.m. Classic rock & roll; electric music for the mind and body from the '60s and '70s.

Radio Theater Sun. 6 p.m. From traditional to experimental, set in the theater of the mind.

Raíces Mon. 7 p.m. & Sat. 2 p.m. Latin American *Freeform* music, all genres of Hispanic music.

Sage Health on Call 2nd Sunday each month, 11 a.m. Alternative and environmental health issues, with live call-in.

Salsa Sabrosa Fri. 7 p.m. Afro-Caribbean-influenced music. Hot!

Singing Wire Sun. noon. Native American music, traditional to today's sounds of folk, C&W, rock.

Southwest Stages Wed. 10 p.m. The region's best performances, recorded live in concert.

Spoken Word Sun. 8 p.m. You know the power of words; now hear the power of poetry. Y mas!

StarDate M-F 7 p.m., Sat. & Sun. 6 p.m. Two-minute travelguide to the universe. What to look for in the night sky, tales of ancient skylore.

Street Beat Fri. 11 p.m. New Mexico's source for live turntablism, mixing and scratching a variety of rare funk, rock, jazz, and soul breaks, from the old to the new.

This American Life Sun. 4 p.m. A quirky look at modern life through fact, fiction and found tape.

This Way Out Fri. 8:30 a.m. International lesbian and gay news magazine.

Tombstone Rock Wed. 10 p.m. Ear-shredding metal music other stations are afraid to play.

Train to Glory Sun. 6 a.m. Sunday morning Black gospel music featuring traditional, contemporary, and local church choirs.

Voces Feministas First Sat. every month, noon. Features the voices of third world women, and women of color.

Weekend Edition Sat. 7 a.m., Sun. 9 a.m. Weekend news magazine from NPR.

Women's Focus Sat. noon. Women's magazine on politics, art, culture, news, and information.

Youth Radio Sun 7 p.m. The voices of NM teens via news, commentary, interviews and music.

RADIO HIGHLIGHTS

thursday jazz noon january 4
you can listen with your eyes, the eyes hear many things, going to concerts is one of the great pleasures of life, watching the drama of an ensemble on stage BUT just for one or two tunes try this: listen with your eyes closed -- host mark weber

Friday, January 5
8 a.m. University Showcase will feature *Cuerpo y Alma: Concept, Form, and Reception in Ibero-American Colonial Visual and Material Cultures*. Our guest will be Ray Hernández-Durán Assistant Professor, Department of Art and Art History.



Dr. Ray Hernández-Durán

Dr. Hernández-Durán will discuss this remarkable collection of art and the distinguished guest speakers who will be featured in the Gale Memorial Speaker series on Colonial Art planned during spring semester 2007. Hosted by Jane Blume and produced by Dick Frederiksen.

Saturday, January 6

6 a.m. New Dimensions. *Deepening Life: Poetic Resonance* with Jane Hirshfield. Jane Hirshfield searches out new ways to increase poetry's capacities for understanding. With each collection she has written, Jane Hirshfield, widely considered as one of America's preeminent writers and poets of her generation, has continued to search out new ways to increase poetry's capacities for understanding. This dialogue is an exploration into the world of poetry, with its depth of thought and richness of observation. An evocative mix of control and wildness shines through each portion of this dialogue. Jane Hishfield was a finalist for the National Book Critics Circle Award, a recipient of the Poetry Center Book Award, the Commonwealth Club of California's Poetry Medal, and fellowships from the Guggenheim and Rockefeller foundations. Program #3170.

Sunday, January 7

11 a.m. Smart City Radio. *Building a Village.* New immigrants are changing America's cities in many ways,

but what is happening in immigrant neighborhoods is not always easily understood. Sandra Ball-Rokeach and Vikki Katz, both at the Annenberg School for Communication at the University of Southern California, are working in the immigrant neighborhoods of Los Angeles to learn how communication flows and what that means to mainstream media and political leaders. Todd Hoffman, president of Collegia, is also speaking. Hoffman works with colleges and communities to attract and retain top student talent.

6 p.m. Radio Theatre.

"*Infidel*" by Roger Gregg (Episodes 1 and 2). *Infidel* was originally a stage play produced by the Graffiti Theater Company in Dublin in 1991. It was a response to what we now call "The First Gulf War" in recognition of the old adage that those who do not learn the follies of history are condemned to repeat them. In the summer of 2005, RTE Radio 1 commissioned Crazy Dog Radio Theatre to adapt and expand the stage play into a 4-episode radio series. The script was re-designed specifically to exploit the epic scope possible in the audio medium. The combination of the realism of the location recordings, vivid sound design, original music score and performances by some of Ireland's leading voice actors, has resulted in an exciting and compelling audio-epic of clashing beliefs, war and compassion.

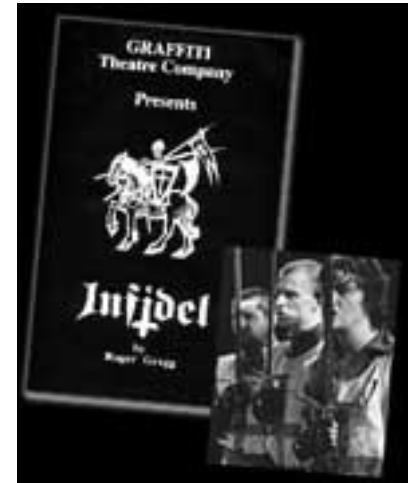

Friday, January 12

8 a.m. Colors of Justice. KUNM's monthly environmental justice program examines a broad range of social issues in New Mexico, from the roots of poverty to health and wellness in our local communities.

Saturday, January 13

6 a.m. New Dimensions. *A Brief History of God*, with Richard Smoley. Join us for this intriguing exploration into the history and evolution of Christianity. Which came first: the bible or the Church? Why are there are no eyewitness accounts of Jesus' presence on earth? Does it matter? When was Jesus first viewed as on a par with God the Father and as part of the Holy Trinity? Richard Smoley is one of the world's most distinguished authorities on the mystical and



Richard Smoley

elements of spirituality that will stretch your consciousness, your notion of good and evil, and life beyond life. Program #3158.

Sunday, January 14

11 a.m. Sage Health On Call. “Heart Healing Heart: Curanderismo in the 21st Century.” Our guest, Elena Avila RN, is a curandera and a registered nurse with a Master’s Degree in psychiatric nursing. Elena will speak with co-hosts Chester Brown Jr, Navajo Martial Arts Instructor, and Dr. John Claussen, Chiropractor at the Bear Canyon Health Clinic. Produced by Halima Christy, Director of Global Sage Health Collective.

6 p.m. Radio Theatre. “Infidel” by Roger Gregg (Episodes 3 and 4). See January 6th listings for details.

Friday, January 19

8 a.m. Backroads Radio. Back Roads Radio. Getting back to the “same old, same-old” after the holidays sometimes takes an extra nudge. How do we turn resistance into reclaiming what we’re here to do? We’ll hear stories reflecting how some folks reconnect to their commitments and find innovative ways to charge on. Back Roads Radio is produced by Viewpoint Productions and hosted by Judy Goldberg.

Saturday, January 20

6 a.m. New Dimensions. Eating for Peace: A Vegan Perspective with Will Tuttle. As Gandhi observed, our fork can be a weapon of violence. Will Tuttle, pianist, composer and teacher, embraces this simple truth by keeping violence off his plate and adopting a vegan way of being in the world. He expresses the heart and soul of the animal liberation and compassionate living move-



Will Tuttle

esoteric teachings of Western civilization. He’s at home with intriguing and complex questions about the history and evolution of Christianity, and how it reflects teachings of the other great wisdom traditions. He brings clarity to the inconsistencies we find in the bible, and sheds light on the reasons for the contemporary resurgence of Gnosticism and the divine feminine. Smoley is at once logical and respectful of the magnificence of faith, and points to

ment with insights that prove how inextricably linked is the suffering of animals with the war, violence and terrorism we currently face on earth. From mythology, religion, and human systems, Tuttle offers a set of universal principles for all people of conscience to show how we as a species can move our consciousness forward – allowing us to become more free, more intelligent, more loving, and happier in the choices we make. Will Tuttle is a professional pianist, composer, and teacher who holds a Ph.D. from the University of California, Berkeley. Program #3163.

Sunday, January 21

11 a.m. American Radio Works. Reports from a Warming Planet. The early signs of climate change are showing up

across vastly differing landscapes: from melting outposts



near the Arctic Circle to disappearing glaciers high in the Andes; from the rising water in the deltas of Bangladesh to the “sinking” atolls of the Pacific. Reports from a Warming Planet takes you to parts of the planet where global warming is already making changes to life and landscape, and demonstrates how climate change is no longer restricted to scientific modeling about the future. It’s happening now.

6 p.m. Radio Theatre. “Anne Manx on Amazonia,” Part I, by Larry Weiner.

Recipient of the 2005 Mark Time Gold Award for science fiction audio. On Amazonia, succession to the throne is simple. The Queen (Barbara Harris) is simply cloned, thus avoiding all manner of complications.



When the queen’s first clone is found to be imperfect, it is discarded and they try again. But the first clone survives! When that clone goes to Earth to get the diamonds she needs to run the cloning machine back on Amazonia (which can repair her imperfections), she seeks out Anne Manx (Claudia Christian), the finest Private Eye in the galaxy, and enlists her help.

Friday, January 26

8 a.m. Peace Talks. The Radio Series about Peacemaking and Nonviolent Conflict Resolution. This month, a profile in peace featuring Ralph Bunche, an often over-looked

name in African-American history. Dr. Ralph Bunche was an educator, mediator and civil rights leader, whose accomplishments, many argue, deserve much more attention than they typically get in the history books. As a mediator and United Nations diplomat, he helped broker the first Arab-Israeli peace accord in 1949 and was the first person of color anywhere in the world to be awarded the Nobel Prize for Peace in 1950. Ralph Bunche died in 1971. To talk about his life and times, we're pleased to have with us on Peace Talks, his son Ralph Bunche Jr., filmmaker William Greaves who produced a PBS documentary on Ralph Bunche, and Sir Brian Urquhart who served with Mr. Bunche and wrote his biography. Paul Ingles is the host with help from professional mediator Tanya Covington. More details on all Peace Talks programs is available at www.peacetalksradio.com.



Ralph Bunche

Saturday, January 27

6 a.m. New Dimensions. Healing Sounds and Shifting Frequencies with Andi & Jonathan Goldman. The Goldmans describe Hindu, Tibetan Buddhist, and other concepts of tantra, and its relationship to sound, vibration, and enlightenment. Have you always thought that tantra was only about sex and that you had to have a partner to do it? Jonathan and Andi Goldman will tell you otherwise. They describe Hindu, Tibetan Buddhist, and other concepts of tantra, and its relationship to sound, vibration, and enlightenment. Jonathan Goldman is an award-winning musician and tantric practitioner who concentrates on expanding all levels of consciousness, from exercises with breath, toning, seed sounds, and sacred vowels, to frequency and intention, all culminating in a balancing of chakras, exchanging energy with others, and experiencing healing and unity with the divine. The Goldmans' teach that using our voices and other sounds in new ways can attract greater harmony and creativity within our lives and relationships. Hosted by Justine Willis Toms. Program #3176.

6 p.m. Reading and Conversation with Deborah Eisenberg and Ben Marcus. Eisenberg is the author of five collections of short stories, "All Around Atlantis," "The Stories (So Far)" of Deborah Eisenberg,"



Deborah Eisenberg

"Under the 82nd Airborne," "Transactions in a Foreign Currency," and the most recent, "Twilight of the Super Heroes: Stories." She is a professor of Creative Writing at the University of Virginia. Marcus is the author of three books of fiction, "Notable American Women," "The Father Costume," and "The Age of Wire and String." Eisenberg will read from her work, then join in conversation with Marcus. Recorded at the Lensic Performing Arts Center in Santa Fe.



Ben Marcus

Sunday, January 28

11 a.m. Circus Blood: Tales from the Big Top. Emcee

John Dankosky, of WNPR- Connecticut Public Radio, presents a world-class troupe of audio daredevils and media magicians: SF Chronicle journalist Jon Carroll interviews



his daughter Shana as she hang upside down on her "Trapeze," ready to fly away; from the Life Stories series by Jay Allison. Joe Frank loves the lady "Lion Tamer," an excerpt from his hour "The Dictator- Part 2." Adam Rosen mixes a medley of the many versions of "The Lion Sleeps Tonight." Drummer Bobby Previte composes the "Music of the Moscow Circus." Elizabeth Eck returns to the circus family she ran away to join in Larry Massett's "Circus in the Blood." And Twink serves up "The Great Circus Show" from The Broken Record.

6 p.m. Radio Theatre. "Anne Manx on Amazonia" Part II, by Larry Weiner. See January 20th listing for details. ■

Thanks!

In the December issue of Zounds! we printed an article featuring one of our volunteers, Elaine Baumgartel, who is also a UNM graduate student. It was reprinted with kind permission from the UNM Alumni Magazine. We also wish to thank the writer, Sammie Lopez, and photographer, Xavier Mascareñas. ■

The “almost pretty good, downright terrific” music list for 2006.

by Matthew Finch, KUNM Music Director

A best of 2006? Not quite. Music’s much too personal, tastes too subjective, and no, we don’t get every single release, so best to consider this a short survey of notable 2006 releases. With one exception: The Handsome Family’s “Last Days of Wonder.” The sweet-bye-and-bye becomes a circle of Hell in this toe-tapping exploration of the great American Gruesome, and these ballads sound right at home alongside the work of David Lynch, Annie Proulx and Flannery O’Connor. In a time when so-called Americana music is growing in scope and innovation, this New Mexico-based group has hit on something singular, and it appears the world beyond “L of E” is taking notice.

Rock Hall of Famers’ Van Morrison and Neil Young made important additions to their catalogs in 2006, and Bob Dylan continued his trajectory into a timeless roots style (& even topped the Billboard charts for the first time in 30 years), but Bruce Springsteen’s “The Seeger Sessions” was the big surprise, in part because this project could have gone so wrong in so many ways. Instead, Springsteen and his robust acoustic ensemble deliver crackling, all-but live versions of songs written or championed by Pete Seeger, in the process celebrating precisely the humor and anger that tend to be lost when we make icons of musicians.

The Brian Lynch/Eddie Palmieri Project’s “Simpatico” falls on the lush side of the Latin Jazz spectrum, but given how difficult it is to assemble, keep and rehearse a large ensemble this group has every reason to show their chops off in elegant surroundings. The album becomes both more elegant and more earthy as local favorite Lila Downs checks in for vocal duty on two cuts.

Warren Zevon may be gone, but he’s not forgotten, not judging by “Switzerland” from The Electric Six. While this hard rocking outfit’s musically on a rather different planet than Zevon, lyrically they’re his bastard children and treat each song on this album as an opportunity for mordant, miserable fun. And in a year where once again Rock was looking for a new wind the guitar & drums (& nothing else) sound of The Black Keys’ “Magic Potion” provided something urgent and smart.

Elegant, eccentric, bewitching and original, “Son” by Argentina’s Juana Molina and “Le Fil” by France’s Camille charted new territory in song style and left most American songwriters looking shabby by comparison.

The passing in 2006 of Ali Farka Toure would be enough to elevate his final completed record “Savanne” to any notable list, but this CD is strong beyond any circumstance of timing. Although his reputation in the states grew as part of an overall interest in international “fusion” and pop, the Malian master more typically presented his work as directly from the source and needing little embellishment beyond amplification. “Savanne” is a study in how songs can be spare and majestic at the same time. A steely opus that allows for rhythm only under extreme pressure,

Dwight Ashley’s “Ataxia” reasserts why ambient music was once called “mood music for post-moderns.”

The mood here is foreboding, but what makes ambients so compelling is that a listener can respond in unexpected ways: you may as easily find yourself blissing out as hiding under the bed.

“Nina Simone: Remixed & Reimagined” – it would be hard to imagine an artist whose fans have less need for the Remix Treatment, but then there are few voices that stand up so well to it. The producers here wisely chose Simone’s late 60s soul & pop sides – including outtakes -- as raw material and approached them with the same careful touch as last year’s remix masterpiece “Impulsive!” For those who’ve heard one too many immortal voices reduced to ghosts in the drum machine, this CD may just restore your faith in Remixes.

Back in 1999 a reporter for Playboy Magazine asked Richard Thompson to submit a “Best of the Millennium” song list (and you thought “Best of the Year” lists were absurd). Thompson’s roundabout answer were the concerts featured on “1,000 Years of Popular Music.” Joined by Debra Dobkin on 2nd guitar and Judith Owen on vocals, his eccentric take on the subject runs from Medieval song through to Britney Spears, and the result is easily the most disarming – and sincere – record of the year.

Since we started in NM, let’s finish here with something for the season. Holiday albums have their virtues, but it’s basically unheard of for an artist to use one as a place of daring musical experiment. On “Pueblo Christmas” Taos’ own Robert Mirabal turns a bunch of airs into a literal tone poem about the new & the old, the here & there and how we remember ourselves in the midst of it. On both sides of these dual flute/cello/drum performances are original pieces celebrating the joy and melancholy of the season on the pueblo.

For more on music notables for 2006, check it out on our website: kunm.org. ■



KUNM
89.9 FM ALBUQUERQUE

Freeform Music
monday-friday
1:30-4pm, and overnight

*the best music you've never heard.
seriously eclectic for the
musically adventurous*

one station, many voices

on 89.9 FM
streaming live at kunm.org

for a free copy of our program guide, call 505.277.3968, or visit kunm.org
simplified graphics studio | singell agnew photography

PROGRAM UNDERWRITERS

Many thanks to the businesses and individuals listed below, who are helping to underwrite the cost of KUNM's programming. Should you have the opportunity, we hope you'll also thank them for supporting public radio! For information on underwriting opportunities, call 277-3969.

1uffakind PO Box 6164, Albuquerque 87197, www.1uffakind.com

abqARTS, Albuquerque's monthly magazine of the arts. www.abqarts.com

Aesops Gables

4810 Pan American Fwy. NE
Albuquerque, 87109

Dr. Jo Anne Allen 4830 Juan Tabo NE,
Albuquerque, 293-7611

Amish Connection of New Mexico

1009 Juan Tabo NE, Albuquerque, 294-2638

Aztec Animal Clinic 4340 Coal SE, Albuquerque, 265-4939

Dr. David Bernitsky, Ophthalmologist
323-0880, www.bernitsky.com

Betty's Bath & Day Spa 1835 Candelaria NW, Albuquerque, www.bettysbath.com

Blue Dragon Coffee House

1517 Girard NE, Albuquerque

Cedar Solar, 1285-J Clark Rd, Santa Fe, 505-474-5445

Celebro, 109 Carlisle Blvd NE, Albuquerque, 265-6403

Central New Mexico Community College
Formerly TVI

Corrales Bosque Gallery, 4685 Corrales Rd., Corrales, NM 87048, 898-3746

Fred & Sandra Creek, Realtors, Coldwell Banker Legacy, www.ABQHomes.com
480-3733

Dan Cron Law Firm, P.C. 125 Lincoln Ave., Santa Fe, 87504, 505-986-1334

Davis Kitchens Albuquerque and Santa Fe, www.daviskitchens.com

Design Warehouse 101 W. Marcy St., Santa Fe, 87501, 505-988-1555

Exit Realty of Albuquerque
2625 Pennsylvania NE Ste 200, Albuquerque, 296-7700

Field & Frame 107 Tulane SE, Albuquerque, 87106, 255-6099

The Firebird 1808 Espinacitas St., Santa Fe, 505-983-5264, thefirebird.com

The Framing Company
2424 Cerrillos Rd., Santa Fe, 505-438-6000

Glass-Rite Replacement Windows

800-824-1005 Glass-rite.com

High Country Macula, Retina, and Vitreous, PC
465 St. Michael's Drive, Suite 205
Santa Fe, 87505, 505-982-5716

Il Vicino Wood Oven Pizza & Brewery
Albuquerque and Santa Fe, www.ilvicino.com

Independent Volvo

1401 Third Street NW, Albuquerque, 87102

Isis Medicine 401 Botolph, Santa Fe, 87505, 505-983-8387

Jiffy Lube www.jiffylube.com

Jim's Automotive 4401 Lead SE, Albuquerque, 87108, 256-1531
www.jimsautomotive.com

Johnson Storage & Moving Company
Santa Fe, 800-876-6683, www.johnson-storage.com

Keshi 227 Don Gaspar, Santa Fe, 87501, 505-989-8728

LaMontanita Co-Op 3500 Central SE, Rio Grande NW at Matthew, Albuquerque

Lewis & Roca Jontz Dawe, LLP

201 3rd NW Suite 1950
Albuquerque, 87102, 764-5400
www.lewisandroca.com

Lieber's Luggage On Manual across from Sears

New Mexico Educators Federal Credit Union
"Until money comes with instructions." Equal opportunity lender; member NCUA.

New Mexico Voice, free publication available at various locations throughout the state. Email Findyourvoice@aol.com to find a location near you.

Osuna Nursery

501 Osuna Rd. NE, Albuquerque, 345-6644

Pachamama 223 Canyon Rd., Santa Fe, 87501, 505-983-4020

Plants of the Southwest 3095 Agua Fria, Santa Fe, 505-344-8830

Presbyterian Hospital Albuquerque

Primetime Monthly News

2403 San Mateo, Suite P-15
Albuquerque, 87110, 880-0470

Roller Printing 1233 Siler Road, Santa Fe, 505-474-5858

Santa Fe Hemp, 105 E. Water St., Santa Fe, 505-984-2599, www.santafehemp.com

Satellite Coffee

Locations throughout Albuquerque

Season's Rotisserie Grill 2031 Mountain NW, Albuquerque, 766-5100

Southwest Women's Health 883 Lead Ave. SE Ste A, Albuquerque, 843-7131

Sportz Outdoors

6915 Montgomery Blvd NE
Albuquerque, NM 87109

Sun Monthly, monthly publication; personal/practical/global.

The Sun-News

PO Box 5588
Santa Fe, NM 87502-5588
505-471-5177

Sunrise Springs Inn & Retreat

242 Los Pinos Rd., Santa Fe
505-471-3600, 800-955-0028

Taos Herb Company, makers of Yerba Hair Care Products, available at Walgreen's and other stores. www.taosherb.com

Ten Thousand Waves

320 Tesuque Dr., Santa Fe 87505
tenthousandwaves.com

Weekly Alibi Albuquerque's news and entertainment weekly, free every Thursday at more than 800 locations; 346-0660; www.alibi.com

Weems Galleries and Framing

Eastdale Shopping Center, 2801-M Eubank NE, Albuquerque, 87112, 293-6133; and in Plaza Don Luis - Old Town, 303 Romero NW, Albuquerque, 87104 764-0302

Wells Fargo Bank of Taos

630 Paseo del Pueblo Sur, Taos, 87571

Whiting Coffee Company

3700 Osuna NE, Albuquerque, 344-9144

Whole Foods Market 5815 Wyoming NE, Albuquerque, 856-0474

Zia Diner, 326 S. Guadalupe, Santa Fe, 505-988-7008. Breakfast, lunch & dinner 7 days a week.



Home of Happy Feet
Tuesdays 7 pm

one station, many voices

on 89.9 FM streaming live at kunm.org

for a free copy of our program guide, call 505.277.3968, or visit kunm.org
simplified graphics studio | singeli agnew photography

Zounds! is published monthly by KUNM as a service to its members. Offices are located in Oñate Hall, UNM, Albuquerque, NM 87131. For display advertising, call Mary Bokuniewicz at 277-8006.

KUNM 89.9 FM is licensed to the Regents of the University of New Mexico as a non-commercial, educational broadcast facility. Studios are located on the UNM campus in Oñate Hall. Our transmitter is located on Sandia Crest and broadcasts with an effective radiated power of 13,500 watts.

KUNM operates FM translator stations in Arroyo Seco, K216AL 91.1; Las Vegas, K220AW 91.9; Taos, K220AV 91.9; Cimarron/Eagle Nest, K216CT 91.1; Socorro, K220EL 91.9; Cuba K216CU 91.1; and Nageezi K220EM 91.9.

KUNM Funding Sources

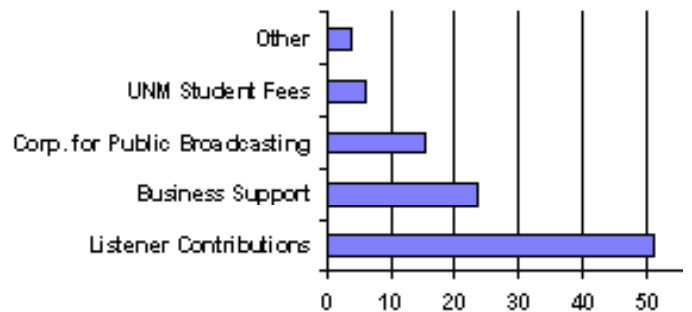

This graph represents inputs to KUNM's annual operating budget. The University of New Mexico makes an annual indirect (non-cash) contribution to KUNM of facilities, staff support and administrative services. In FY '00, UNM's contribution to KUNM was valued at \$125,000.

KUNM programming is made possible in part by a grant from the Corporation for Public Broadcasting.

Most of KUNM's local programming is produced and hosted by volunteers, including students and community members. Their contributions provide an invaluable service to KUNM and its listeners.

Funding for KUNM training programs is provided in part by students at the University of New Mexico. These funds are allocated to KUNM by the Student Fee Review Board in consultation with the Associated Students of the University of New Mexico and UNM's Graduate and Professional Student Association.

To protect the privacy of our contributors, it is the policy of KUNM to refrain from any form of mailing list exchange with any for-profit, non-profit or political organization. KUNM does not trade or sell its membership lists to any outside entity.

The University of New Mexico is an Affirmative Action/Equal Opportunity institution. In accordance with the Americans with Disabilities Act, this material is available in alternate formats upon request. For information, call 277-3968. KUNM is a member of the Albuquerque/Santa Fe/Los Alamos Equal Employment Opportunity Council.



Accurate Inexpensive Piano Tuning

Accoustic ■ Concert ■ Electric ■ Home

Minor Adjustments

Serving the area since 1975.

Arnold Bodmer (505) 286-3364

January 2007
Zounds!
MONTHLY PROGRAM GUIDE

KUNM 89.9 FM

89.9 ALBUQUERQUE ♦ 89.9 SANTA FE ♦ 91.9 TAOS ♦ 91.1 CIMARRON/EAGLE NEST
91.1 ARROYO SECO ♦ 91.9 LAS VEGAS ♦ 91.9 NAGEEZI ♦ 91.9 SOCORRO ♦ 91.1 CUBA

Zounds! is available online at kunm.org.

*Native America Calling
welcomes back an
old friend!*

*And, the digital
transmitter is place,
now how about
the combiner?*

*Plus, January
program listings
and more . . .*

Stay tuned!



K · U · N · M
89.9 FM ALBUQUERQUE

MSC06 3520, Oñate Hall
1 University of New Mexico
Albuquerque, NM 87131-0001

Address Service Requested

Non-profit organization
U.S. POSTAGE
PAID
Albuquerque, NM
Permit No. 39

TIME VALUE MATERIAL
DO NOT DELAY

1-07

Zounds is available online in pdf format, at kunm.org. If you would like an email notification each time a new issue is posted, **INSTEAD OF** receiving a paper copy, email your request to membership@kunm.org